



3D DISPLAY FROM MRI OF A BRAIN HEMISPHERE SHOWING SULCI AND CONNECTIONS.

## A UNIQUE IMAGING PLATFORM

The goal of NeuroSpin is to push the current limits of brain imaging, from the mouse to man, as far as possible with very high magnetic field Nuclear Magnetic Resonance (NMR). NMR imaging (MRI) can be used to observe deep organs totally non-invasively. The more intense the magnetic field, the greater the sensitivity, allowing more details to be seen. Benefiting from CEA know-how in the conception of magnets and NMR, this technical platform will be equipped with unrivalled NMR imaging tools.

Located in Saint-Aubin, within the CEA Saclay center, this imaging platform will be unique in Europe. It will bring together exceptional resources and very efficient tools (original superconducting magnets, powerful computers, laboratories, multidisciplinary teams...). It will complete the existing installations at the Service Hospitalier Frédéric Joliot in Orsay dedicated to radioisotope imaging and, in particular, positron emission tomography (PET).

Grouping physicists and neurobiologists, in close collaboration with other government research agencies and universities, in particular from the Paris Region, open to the national and international community, the NeuroSpin platform will co-ordinate research, provide a network of skills and an optimisation of means. About

150 researchers, physicians, students, engineers, technicians, ... are expected to develop innovative tools and methodologies, and apply them to neurobiology at large, from neurogenetics and neurophysiology to cognitive neurosciences and clinical neurology.

Federating a great many regional, national and international partnerships, NeuroSpin will be a true drive towards technological innovation and distribution that will also contribute the industrial and economic fabric of the Paris Region.

3T MRI SCANNER AT SERVICE HOSPITALIER FRÉDÉRIC JOLIOT (SHFJ).

3D DISPLAY OF MRI (ANATOMY) AND PET IMAGES (DISTRIBUTION OF NEUROTRANSMITTERS IN THE BASAL GANGLIA).

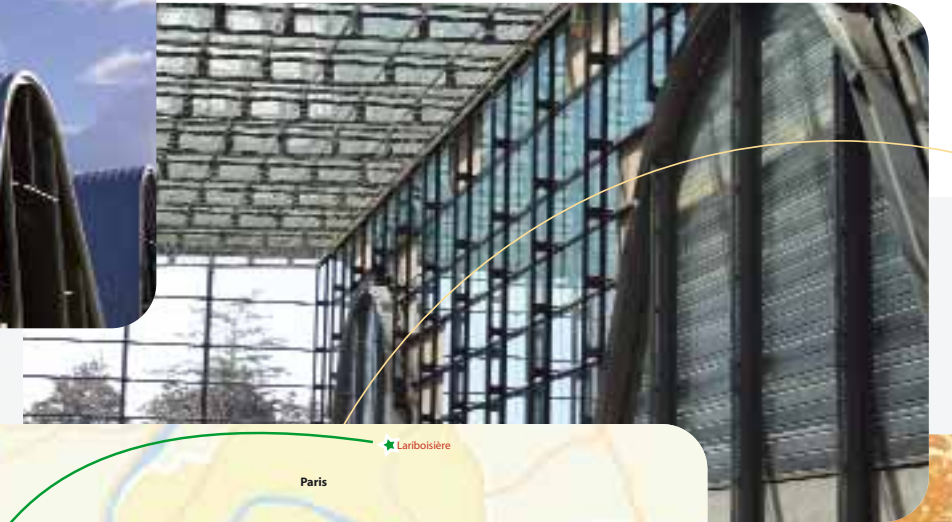

**NeuroSpin**  
CEA Saclay, Building 145  
91191 Gif-sur-Yvette Cedex

**CEA**  
**LIFE SCIENCES DIVISION**  
18 ROUTE DU PANORAMA  
92265 FONTENAY-AUX-ROSES CEDEX  
[www-dsv.cea.fr](http://www-dsv.cea.fr)



# NeuroSpin

INTENSE FIELD  
NEURO-IMAGING CENTER

A WINDOW TO THE WORKINGS  
OF THE BRAIN

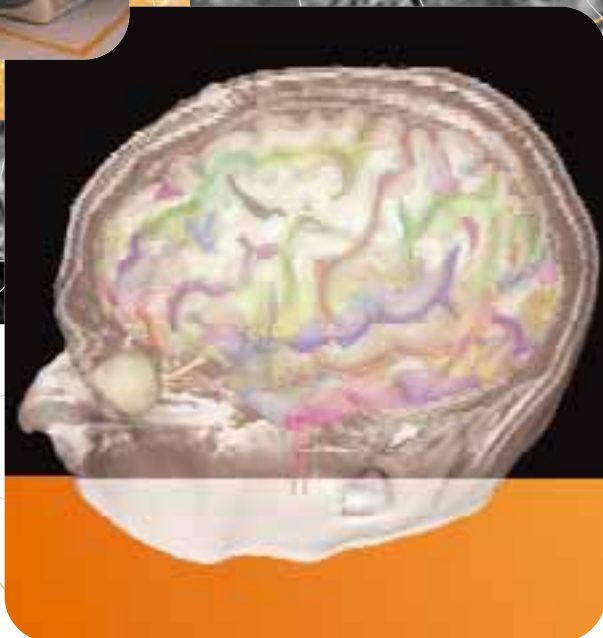
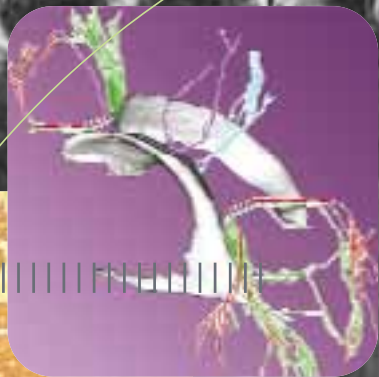

## FROM PHYSICS TO THE BRAIN

CEA is a key player in research, development and innovation in life and health sciences.

A better understanding of how the human brain works will have a direct impact on health care (neuroradiology and medical imaging, neurology, neurosurgery, adult and child psychiatry, ...), but also on society (communication between individuals, education, ergonomics...).

This quest for an understanding of the brain is a major scientific and technical endeavor which requires close cooperation between a number of experts of many disciplines, such as physics, mathematics, data processing, neurosciences, human and social sciences, ...

The CEA's ability to develop and innovate is the result of its deep rooted crossed culture of engineers, researchers and physicians. This well-mixed environment is found in top-level basic and applied research, a necessary requirement for the emergence of new concepts.

Within this setting, CEA houses several centers to design, develop and make available all of the major physical instruments dedicated to in vivo imaging. NeuroSpin is one of them, fully dedicated to the study of the functional architecture of the human brain.

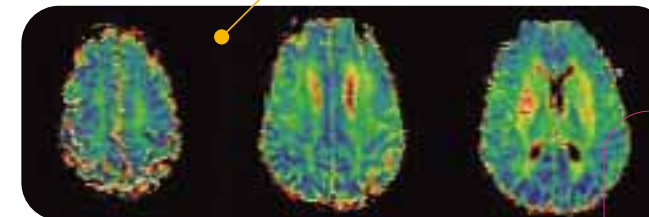

WATER DIFFUSION MRI IN A PATIENT SUFFERING FROM CADASIL (GENETIC DISEASE) DEMONSTRATING ANOMALIES IN THE CEREBRAL WHITE MATTER (SHFJ/HÔPITAL LARIBOISIÈRE COLLABORATION).

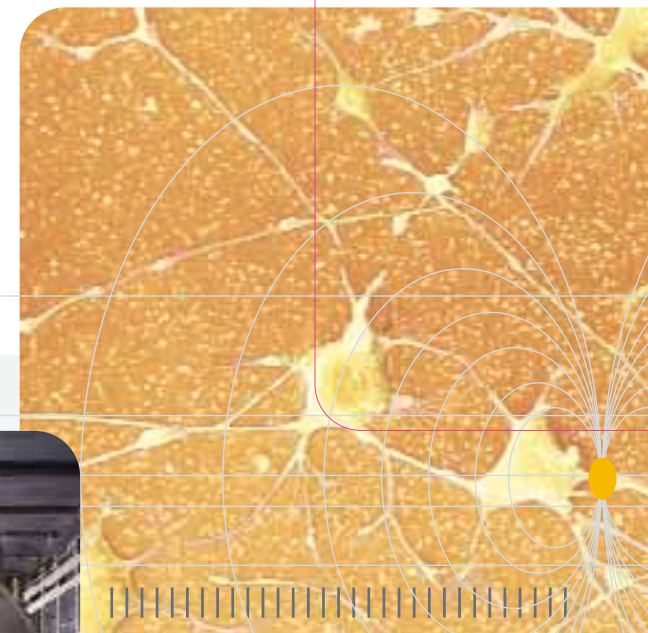

7 TESLA MRI SYSTEM INSTALLED AT NEUROSPIN.

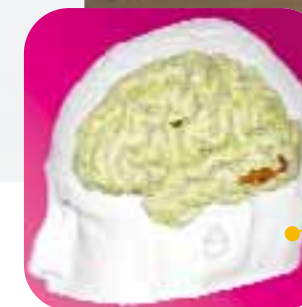

BRAIN IMAGING CONFIRMS THE HYPOTHESIS OF THE SUBLIMINAL PERCEPTION OF WORDS. IT IS POSSIBLE TO SHOW THAT A SUB-UNIT OF THE REGIONS INVOLVED IN THE CONSCIOUS READING PROCESS IS ALSO UNCONSCIOUSLY ACTIVATED DURING THE SUBLIMINAL PRESENTATION OF WORDS.

Each year, a growing percentage of the population in the developed countries suffers from neurological or psychiatric diseases. Large amounts of money are spent for the treatment and rehabilitation of these patients. Life expectancy is increasing and the potential benefits from research on the workings of the brain in an ageing population are obvious. In addition, this research can also greatly benefit our societies by, for example, providing a deeper understanding of the communication processes between individuals, group behaviour or the optimization of learning methods.

New types of « biological » computers based on the workings of the brain may be designed. The man-machine interface (robot design, ergonomics of plane cockpits or car dashboards, ...) may be improved by our understanding of the workings of the brain. The stakes involved are huge and the even partial understanding of the human brain is one of the challenges of this century.

## UNDERSTAND THE BRAIN BY THE IMAGE

In this exploratory quest, neurofunctional imaging has overwhelmed the life sciences. It now has a unique place by providing in vitro and in situ data on the workings of all living organisms in a non invasive manner. It not only completes, but it also sharpens the biological data coming from other approaches (such as molecular biology and electrophysiology...).

The images obtained provide both anatomic data (arrangement of tissues in organs) and functional data (metabolic status, for example). In general, biomedical imaging has imposed itself over the last few years in a great many areas of biology and medicine. It has mainly developed in two directions: functional cerebral imaging and molecular imaging.

- Functional cerebral imaging involves the study of human cognitive processes in the normal and diseased brain. It aims at connecting the upper cognitive functions (perception of objects, language, attention, memory, logic, action...) with their biological component, their neural correlates. Neuro-imaging has today become indispensable in the cognitive neurosciences. It is used to understand the cerebral bases involved in human cognitive processes in both normal subjects and in patients.

- Molecular imaging involves the development of imaging methods to watch the workings of the cells. Associated with functional genomics it will eventually help translate the huge deposit of knowledge on the genome into functional data that can be used in physiology, physiopathology or pharmacology. With such tools it is becoming possible to watch, functionally and anatomically, the development of the brain of mouse embryos and to monitor how gene defects can translate into anatomical or functional abnormalities later in life. The understanding, prevention or treatment of neurological diseases caused by genetic or acquired anomalies during the development of the brain is a major stake involved at NeuroSpin. Industrial partnerships governed by a Franco-German agreement are currently being set up to develop both the imaging systems (Siemens, Bruker) and the biological tracers to be deployed (Guerbet).

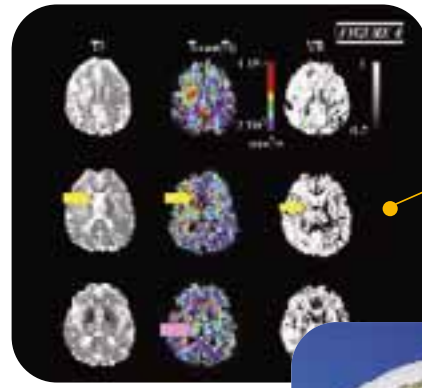

MRI IMAGES SHOWING THE BRAIN REGIONS THAT WERE SUBJECT TO INFARCTION IN A STROKE PATIENT (SHFJ/HÔPITAL LARIBOISIÈRE COLLABORATION).

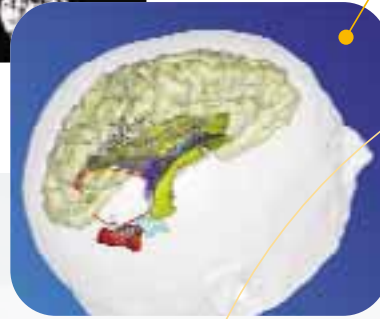

3D DISPLAY FROM MRI IMAGES SHOWING THE STRUCTURES INVOLVED IN THE READING OF WORDS AND THEIR CONNECTIONS. THE CONNECTIONS ARE INTERRUPTED IN THIS PATIENT WITH A LESION OF THE CORPUS CALLOSUM.

Biomedical imaging still comes up against a certain number of technical constraints that limit its potential: the current resolution in space (millimeters) greatly exceeds the size of the neurons, the functional units underlying brain activity; the temporal resolution is generally close to the second when the millisecond would be more representative of the processes involved; the parameters visualised (such as blood flow) only indirectly reflect the functioning of the neurons.

To overcome these obstacles and push the current limits in imaging as far as possible, CEA has decided to build a technical platform where unequalled imaging tools will be developed and used. Nuclear magnetic resonance (NMR) has been chosen as the privileged physics modality.

NMR is based on the magnetic properties of the nuclei of atoms. It uses a magnet with a high and homogenous magnetic field, as well as specialized electronic and computer equipment. NMR provides access to a great many different molecules and physical parameters in a non-invasive manner and without the use of radioactive isotopes. Measuring very low tissue magnetisation, NMR can be used to obtain a very precise, tridimensional view of deep organs. The greater the magnetic field, the higher the sensitivity, and the higher the spatial or temporal resolution that can be achieved.

## VERY HIGH FIELD MAGNETIC RESONANCE

Most NMR imaging systems (or MRI) currently installed in hospitals operate with magnetic fields that do not exceed 1.5 T\*.

The development of more ambitious research protocols requires apparatus with a higher field (>3 T). Recently, very high field devices operating at 7 or 8 T for studies on man have been developed in the U.S.A. Magnets with high and homogenous magnetic fields are at the heart of the NMR apparatus developed. They are made of superconducting wires cooled in liquid helium.

« Turnkey systems » operating at 4.7 T and 9.4 T already exist for animal studies. They are used for quasi-industrial biological or pharmacological applications. Even more efficient systems are available with 11 T or even 17 T magnets with diameters ranging from 10 to 40 cm. For human applications, the design of magnets capable of the utmost field intensity, beyond 10 T, on diameters close to 1 m remain a technological challenge. Facing this technological challenge, NeuroSpin will be equipped with several types of intense field nuclear magnetic resonance (NMR) imaging units:

- 3T system for clinical trials (involving both volunteers and patients),
- 7T system for clinical trials (involving both volunteers and patients),
- 11.7T system for clinical trials (involving both volunteers and patients) scheduled for 2010,
- 17.65T system for preclinical trials in transgenic mice and rodents (scheduled for 2008),
- a fifth platform set aside for the development of future ultra-high-field MRI applications.

(\*) the tesla is the magnetic field unit : the terrestrial magnetic field in Paris is 0.00005 tesla

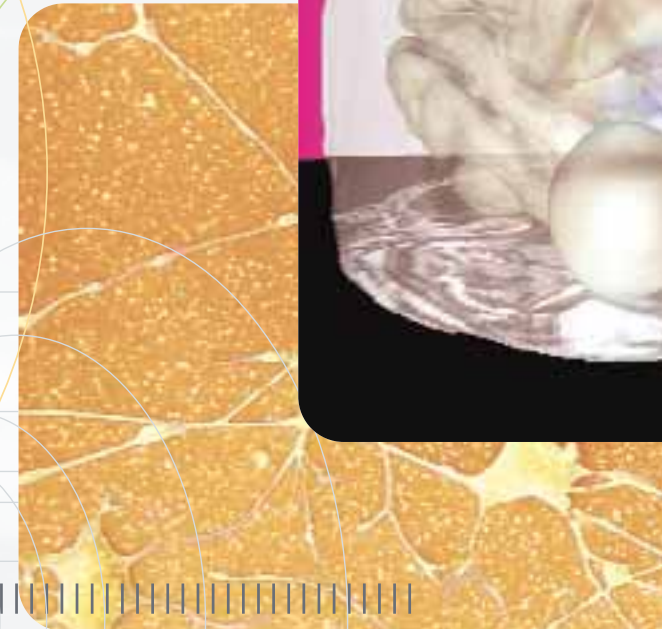
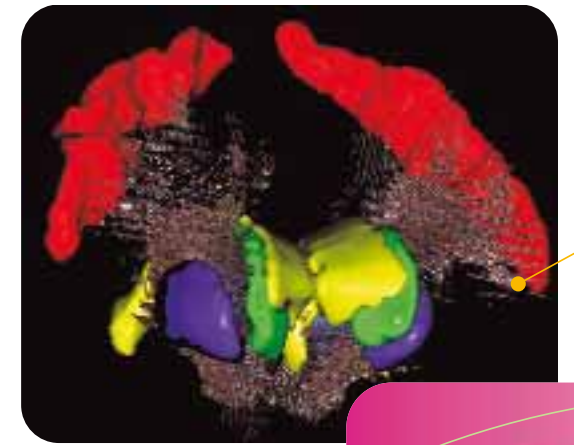

The know-how in the design of those magnets is also a specificity of CEA (Matter Sciences Division) which already contributes to the equipment of particle accelerators at CERN and the creation of associated detectors.

**THE ORIGINAL ASPECT OF NEUROSPIN IS TO BRING TOGETHER TOP-LEVEL METHODOLOGISTS AND NEUROBIOLOGISTS IN THE SAME PLACE:**

Together and in synergy, they will develop the tools and models required to push back the limits of imaging in the exploration of the brain as far as possible. These methodologies will help better understand the workings of the human brain as well as its anomalies during development and dysfunction.

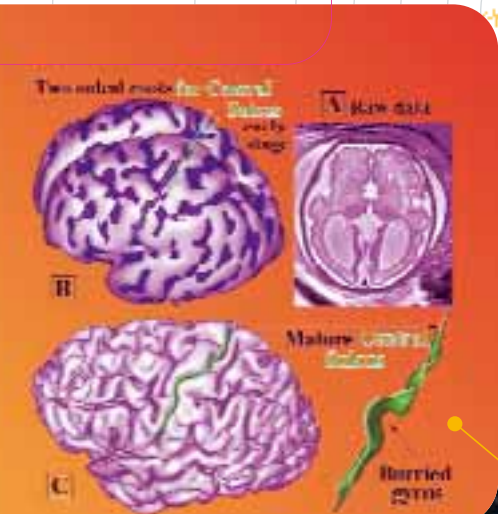

3D RENDERING FROM MRI IMAGES OBTAINED IN A FOETUS IN UTERO SHOWING THE STATUS OF DEVELOPMENT OF THE BRAIN FOLDING PATTERNS. (SHFJ/ HÔPITAL NECKER COLLABORATION).

3D RENDERING OF MICROSCOPY MRI IMAGES OBTAINED IN A MOUSE EMBRYO 13.5 DAYS AFTER CONCEPTION (COURTESY OF R. JACOB, CALTECH).

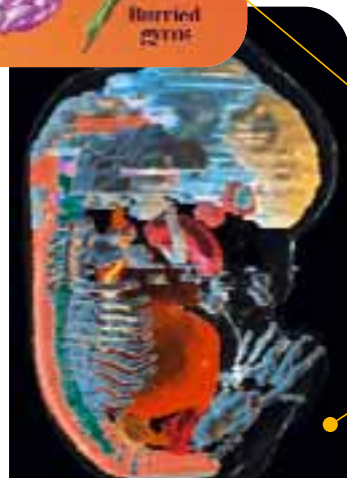

3D DISPLAY FROM MRI IMAGES OF THE MOTOR CORTEX AND CENTRAL STRUCTURES AS WELL AS THEIR CONNECTIONS.

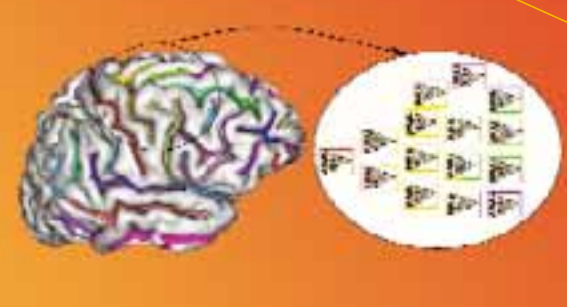
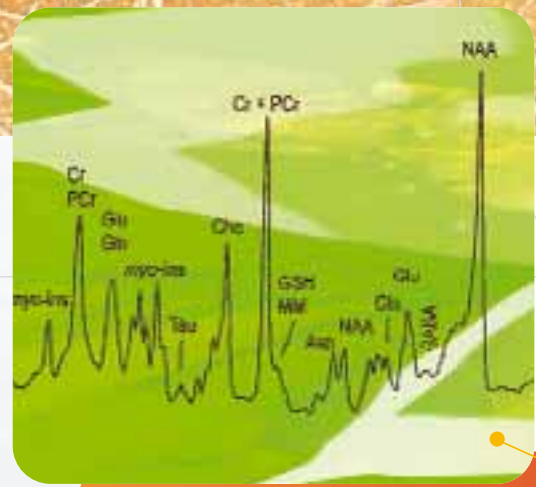
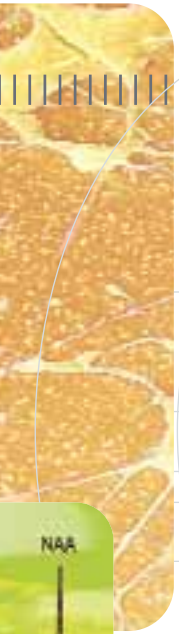
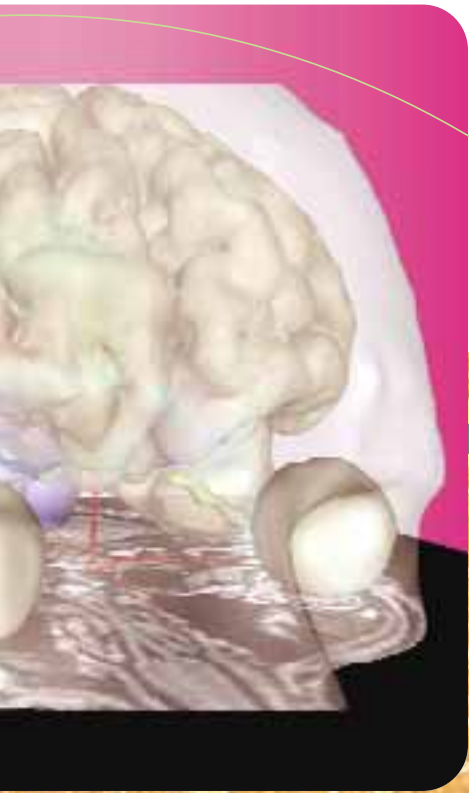

# A GREAT INSTRUMENT FOR THE NEUROSCIENCES

## AN INTERFACE BETWEEN PHYSICIANS AND NEUROBIOLOGISTS

About 150 researchers, physicians, clinicians, biologists, engineers and technicians will work together at NeuroSpin

- The methodology teams will be in charge of pushing the current technical limits of imaging and create new approaches, from imaging methods to mathematical models and software for image analysis, to map the basic biological parameters needed to understand the brain.
- The neuroscientists, neuropsychologists, and clinicians will benefit from these methodological contributions for their own research programs, whether it consists of molecular or cellular biology, neurobiology of development and post-genomics, neurosciences or cognitive sciences.

This specific interface between methodologists, neurobiologists and physicians creates an exceptional environment necessary to break the current limitations of neuroimaging in order to better understand the workings, development and dysfunction of the human brain.

## A CENTER WITH A NATIONAL AND INTERNATIONAL PROFIL

This center, with a national and international vocation, combining "avant-garde" methodology developments and applications in neurobiological areas of the highest interest, will update and complete the Paris region imaging platform network. These equipments, as well as that of nearby existing centers will comfortably position itself in Europe facing similar set-ups in other prestigious institutions, such as NIH or the Harvard-MIT complex in the U.S.A.

NeuroSpin is acclaimed as a major European research infrastructure and has attracted interest from the European Commission.

The teams of NeuroSpin contribute to the School of the neurosciences of Paris Ile-of-France area (ENP), which has the ambition to help to understand the pathological mechanisms responsible for physical or psychic major handicaps.

With this national and international profil, NeuroSpin will aim at becoming part of a European Excellence network. An integral part of the CEA Saclay center near the Institut National des Sciences et Techniques Nucléaires, located in the village of Saint-Aubin (Essonne), NeuroSpin falls within the methodological complementarity of Service Hospitalier Frédéric Joliot (SHFJ) in Orsay where a technical platform for radio-isotopic imaging is already found. This platform is unique in Europe. Their geographic proximity and their management by the same agency are keys to success.

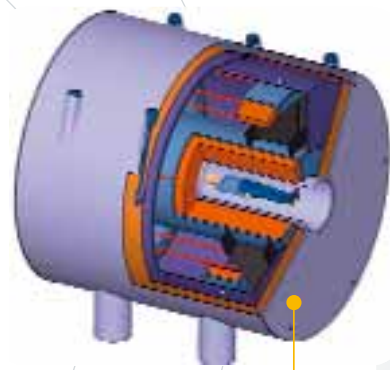

MODEL OF THE MAGNET TO 11,75 T FOR THE MRI SYSTEM : AN INSTRUMENTAL CHALLENGE.

NMR SPECTRUM OF THE BRAIN REVEALING THE PRESENCE OF A GREAT MANY CHEMICAL COMPLEXES INVOLVED IN THE WORKINGS OF THE BRAIN (NEUROTRANSMITTERS, METABOLITES). SPECTRUM OBTAINED IN MAN WITH 7 T (COURTESY DR. TKAC, CMRR, MINNEAPOLIS).



3T MRI SCANNER AT SERVICE HOSPITALIER FRÉDÉRIC JOLIOT (SHFJ)



SERVICE HOSPITALIER FRÉDÉRIC JOLIOT IN ORSAY

# A GROUPING OF RESOURCES FOR A REGIONAL POLICY

The proximity of these instruments with the university campus of Orsay, the Nuclear Physics Institute (IPN), Nuclear and particle physics (IN2P3), the French National Center for Scientific Research (CNRS) laboratories in Gif-sur-Yvette (in particular in the fields of neurosciences and NMR), Institut d'Optique and the schools of engineering, as well as the partnerships formed long ago within the SHFJ between CEA, CNRS, INSERM (The French Institute of Health and Medical Research), Public Assistance to the Hospitals of Paris (AP-HP), the universities (Paris XI and Paris VI in particular), the schools of engineering ("Grandes Ecoles": ENST, Polytechnique, ENS, Supélec, Centrale,...) federate human skills and technical resources.

- Created 40 years ago, the Service Hospitalier Frédéric Joliot (SHFJ) is now at the heart of the Institut Fédératif de Recherche (IFR 49: Neuro-functional Imaging) which federates teams from several research agencies.
- The center in Fontenay-aux-roses (CEA) is planning the construction of a gene therapy platform (MIRcen) that will complete the SHFJ and NeuroSpin installations.
- CIERM (Hôpital de Bicêtre) is developing MRI methods for clinical purposes, in particular in the cardio-vascular field and very high resolution MRI. It trains a large number of imaging clinicians in the Paris Region.
- The Pitié-Salpêtrière hospital complex (AP-HP, French Muscular Dystrophy Association AFM) already has strong links with SHFJ with very active collaborations in neurology, neurosurgery and psychiatry. It plans to obtain a MRI instrument operating at 3 T. This complex also has a Magnetoencephalography (MEG) research center (LENA) of the highest level and is currently testing Transcranial Magnetic Stimulation (TMS).
- INRIA (The French National Institute for Research in computer science and control), INRA (The French National Institute of Agronomic Research), The Pasteur Institute and or the Evry Genopole also are potentially interested in the development of this technical platform.

Established near the SOLEIL synchrotron project, NeuroSpin will benefit from the planned infrastructures (service areas, housing...) to welcome students, researchers, new research teams or for the establishment of industrialists interested in these activities. Patent applications, transfer to industry, development of small and medium-size industry responding to the need for aid in imaging (design of protocols, creation of data banks, optimization of data acquisition, data processing,...), teams of hospital technical platforms or transient collaborators will certainly arise from NeuroSpin. NeuroSpin, component of the world competitiveness cluster MEDICEN Paris Region in the domain of medical imaging, will help make the « Saclay plateau », in the south of Paris, a privileged place for the development of research centers, major physical and biological instruments as well as an important industrial, scientific and technical network.

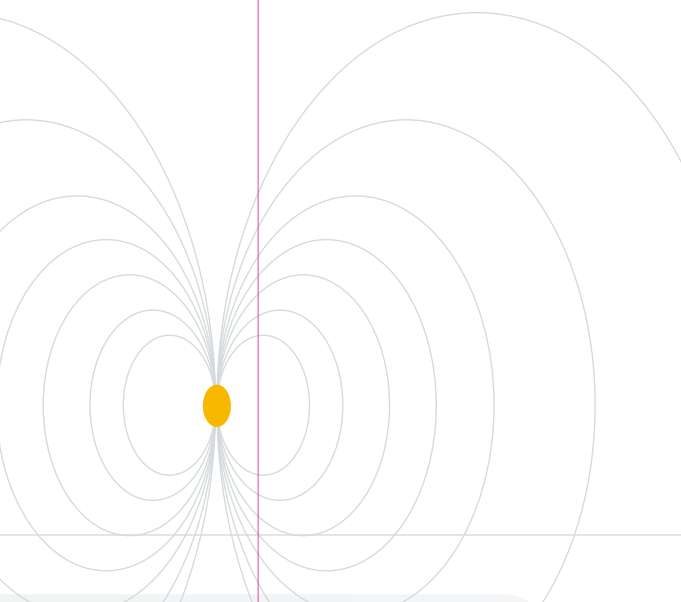

SHFJ POSITRON EMISSION TOMOGRAPHY CAMERA (TEP).

